

Think safety think Steelmate



©Steelmate Co., Ltd. All rights reserved.
The trademark, patent and copyright are owned by Steelmate Co., Ltd.
The right to change the design and specifications reserved.

STEELMATE CO., LTD.

Steelmate Industrial Park, Heping Street, Dongfu Road, Dongfeng Town,
Zhongshan City, Guangdong, P.R. China 528425



PRI0000R/A

STEELMATE[®]
Automotive

PTS411EX

Dual-Purpose Parking Assist System (Front or Rear)



Manual

Contents

User Manual

Important notice -----	01
Disclaimer -----	01
About the product -----	02
2 or 4-sensor automatic recognition -----	02
Key features -----	02
Optional extension cable -----	03
Specifications -----	03
Buzzer or optional Display -----	03
Buzzer volume and frequency adjustment -----	04
Front or Rear system optional -----	04
Sensor installation height -----	05
Activated by pressing footbrake -----	05
Dual intelligent function for spare wheel -----	06
Self-testing function -----	07
Learning function -----	09
How does the system work -----	13
Different scenarios for system with buzzer -----	14
Attention -----	17
Sensor maintenance -----	17

Installation Manual

Brief installation diagram -----	18
Includes -----	19
Installation tools -----	19
Sensor installation -----	20
Buzzer installation -----	27
Wiring diagram -----	28
Functional test -----	31
Troubleshooting -----	32

User Manual

Important notice

Parking Assist System (PTS) helps to provide assistance when reversing and parking. Driving skills such as slowing down, use of mirrors are always essential.

1. This system is for vehicles with DC 9~27V only.
2. This system should be installed by a professional auto technician.
3. Route wiring harness away from heat source and electrical components.
4. It is strongly recommended to check the position of the sensors before the actual drilling of the holes.
5. Perform a functional test after installation.

Disclaimer

The PTS is designed as a driver assistance device, and should not be used as a substitute for safe parking practices. The area into which the vehicle is to be reversed must be constantly monitored while parking.

The manufacturer and its distributors do not guarantee or assume liability for collisions or damages while reversing and braking the vehicle.

About the product

The PTS411EX comes with 4-senor parking system that can be used as a front or rear ultrasonic distance monitoring device (Dual-purpose). It electronically detects the area in front or behind the vehicle while reversing and driving forward.

If the system detects an obstacle, it will have alerts with audible tones and visual warnings. It assists the driver when parking and in manoeuvring situation.

All the detachable sensors are waterproof and can be easily changed. Combined with the anti-interference and anti-false alert technology, the system can detect obstacles in any weather conditions and response quickly. The system has intelligent detection, which is ideal for vehicles with tow-bar or spare tire.

Each part of this system has passed the most stringent test before releasing to the market. It is reliable at a wide storage temperature range and becomes very useful when you are parking at a raining day, snowing day or at night etc. With the help of parking assist system, you can enjoy a comfortable, relaxed and safer parking experience.

2 or 4-sensor automatic recognition

The parking system can be used as a 2-sensor system when fitted on either the front or rear of vehicle. When using as a 2-sensor system make sure you connect the two sensor to either B&C port or A&D port on the ECU (please refer to page 28).

Key features

- Dual-purpose parking assist system, can be used as a front or rear kit
- Can be used as a 2-sensor system (2 front or 2 rear)
- Buzzer can be upgraded with a visual display
- Self-testing function
- Anti-false alert technology
- Dual intelligent function together with learning function for vehicle with tow-bar, spare wheel or other protrusions

Cable length

Sensor wire length 4.5m.

Specifications

Operating voltage: DC 9~27V
Operating current: <250mA
Buzzer SPL: 80±10dB

Operating temperature:

ECU: -40°C~+80°C/ -40°F~+176°F
Buzzer: -40°C~+80°C/ -40°F~+176°F
LED display: -40°C~+80°C/ -40°F~+176°F
LCD display: -20°C~+70°C/ -4°F~+158°F

Storage temperature:

ECU: -40°C~+85°C/ -40°F~+185°F
Buzzer: -40°C~+85°C/ -40°F~+185°F
LED display: -40°C~+85°C/ -40°F~+185°F
LCD display: -30°C~+80°C/ -22°F~+176°F

Detection range:

Front: 0.30~0.99m/ 1.0~3.2ft
0.30~0.59m/ 1.0~1.9ft
(reversing)
Rear: 0.30~2.59m/ 1.0~8.5ft

Buzzer or optional Display

The system comes with a buzzer can be upgraded to display.

Below buzzer/display graphics are for reference only.

More displays are available for selection.

Tips: Some displays are with SET button, digital number distance indication and volume adjustable function.



Display (optional)

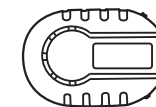

Buzzer

Buzzer volume and frequency adjustment

Volume adjustment

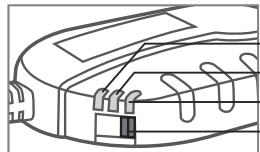

Low volume
Medium volume
High volume
Volume switch

Frequency adjustment

The buzzer sound frequency can be adjusted to High/Low by turning the frequency switch.

Tips: If front sensor system with buzzer installed together, recommended to use low frequency "L" sound alarm for rear system and high frequency "H" sound alarm for front system for distinguish 2 system alarms easily.

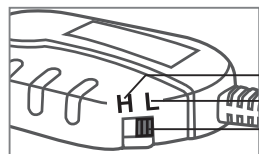

High frequency sound
Low frequency sound
Frequency switch

Front or Rear system optional

The system can be used as a front or rear parking system. Please achieved by changing a jumper on the ECU before installation.

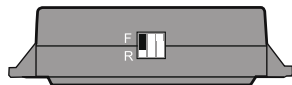

Jumper position: "F"
The system is being as Front system



Jumper position: "R"
The system is being as Rear system

Sensor installation height

The system can be changed the sensor installation height, please achieved by changing a jumper on the ECU before installation.

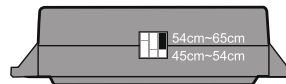

Jumper position: "54cm~65cm" (Default setting)
Recommended setting for sensor installation heights between 54cm~65cm from the ground



Jumper position: "45cm~54cm"
Recommended setting for sensor installation heights between 45cm~54cm from the ground.

Activated by pressing footbrake (Front system)

This function is being used as a front system (jumper position in "F"). The front system is activated by pressing the footbrake. When you press the footbrake and release it the system will continue to work.

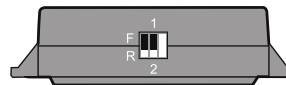

Jumper position: "1" (Default setting)
The system continues to work for 8 seconds
Recommendation: For Automatic

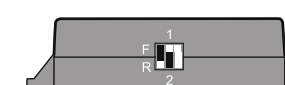

Jumper position: "2"
The system continues to work for 20 seconds
Recommendation: For Manual Cars

Dual intelligent function for spare wheel (Rear system)

This function is being used as a rear system (jumper position in "R").
When this function is ON, the detected distance will increase 20cm (from 30cm to 50cm) between the sensor and obstacle which is designed for the tow-bar or spare wheel.

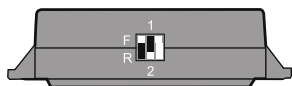

Jumper position: "1"
(Default setting)
Normal detected distance

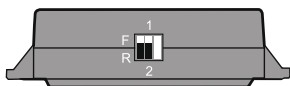
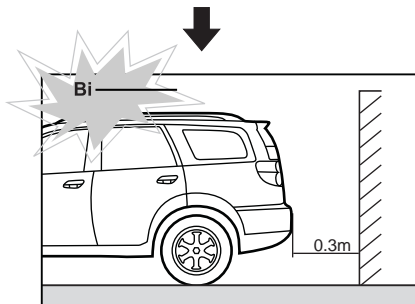

Jumper position: "2"
The detected distance between the sensor head and the obstacle will be increased by 20cm

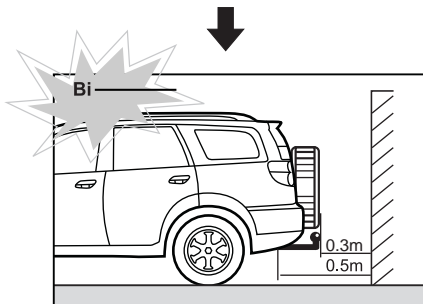

Note: The optional display will still show a reading of 0.3m before -P when the jumper is in position 2.

Self-testing function

For Front System:

Once ACC on, the system will test all front sensor automatically.
If all sensor are working properly, the buzzer will not have alert.
If a damaged or defective sensor is detected, then the system will "Bi" 3 times for alarm.

After self-testing function, the system will continue working for 8 seconds (jumper position "1" in ECU) or 20 seconds (jumper position "2" in ECU) when the vehicle is moving closer or away from the obstacle.

For buzzer

All sensors are working properly

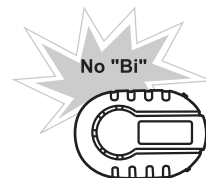

Damaged or defective sensor is detected.

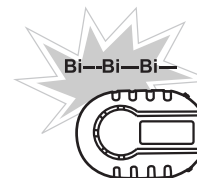

Notes:

- Once sensor(s) is (are) damaged or defective, the buzzer will "Bi" for 3 times to indicate the sensor(s) is (are) damaged or defective.
- The system will not alarm when sensors (A&D), (B&C) are damaged/ defective as it will work as 2-sensor front system automatically.

For Rear System:

When reverse gear is selected, the system will test all rear sensor automatically.

If all sensor are working properly, the buzzer will "Bi" once.

If a damaged or defective sensor is detected, then then system will "Bi" 3 times for alarm.

For buzzer

All sensors are working property

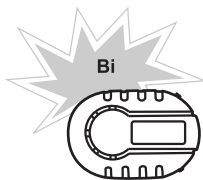

Damaged or defective sensor is detected.

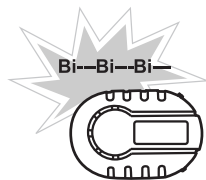

Notes:

- Once sensor(s) is (are) damaged or defective, the buzzer will "Bi" for 3 times to indicate the sensor(s) is (are) damaged or defective.
- The system will not alarm when sensors (A&D), (B&C) are damaged/ defective as it will work as 2-sensor front system automatically.

Learning function

Learning function for cars with nudge bars or other protrusions (Front system)

Please find a no obstacle place to activate this function.

1. With the ignition "ON", press and release the footbrake 10 times with 1 second intervals.
2. On the 10th times, hold the footbrake down , the buzzer will "Bi" once after 5 seconds, then has a long "Bi" sound for 2 seconds after 3 seconds to complete the learning process.

Clear the learning function:

1. With the ignition "ON", press and release the footbrake 12 times with 1 second intervals.
2. On the 12th times, hold the footbrake down, the buzzer will "Bi" once after 5 seconds, then "Bi" once again after 3 seconds to complete the clearing process.

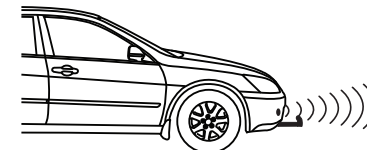
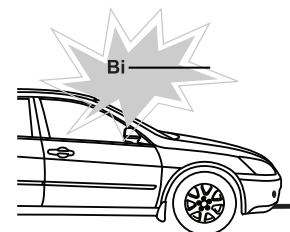

Note:

- This function is valid and acievable only if all sensors are working properly.
- The above procedure must be carried out with 3 minutes of the ignition being switched on. If the ignition has been on for over 3 minutes turn the ignition off and back on again.
- If you make a mistake while carrying out the above procedure, release the footbrake for 3 seocnds to clear the system memory and then start the procedure again.
- If the vehicle does not have nudge bars or other protrusions, you do not need to use this function.
- Perform a functional test after learning function is set.

Learning function for cars with tow-bar or spare wheel (Rear system)

Please find a no obstacle place to activate this function.

1. With the ignition "ON", change the gear from "N" to "R" for 10 times (each gear change must be within 1 second).
2. On the 10th times, leave the gear in "R" position, the buzzer will "Bi" once after 2 seconds, then has a long "Bi" sound for 2 seconds after 3 seconds to complete the learning process.
3. When the learning function is activated, the system will ignore the tow-bar or spare wheel and only detect behind the vehicle.

Clear the learning function:

1. With the ignition "ON", change the gear from "N" to "R" for 12 times (each gear change must be within 1 second).
2. On the 12th times, leave the gear in "R" position, the buzzer will "Bi" once after 2 seconds, then "Bi" once again after 2 seconds to complete the clearing process.

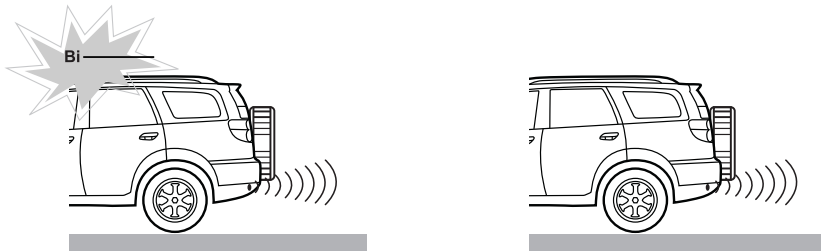

Note:

- This function is valid and achievable only if all sensors are working properly.
- If you make a mistake while carrying out the above procedure, leave the gear in "R" position for 2 seconds to clear the system memory and then start the procedure again.
- If the vehicle does not have tow-bar or spare wheel, you do not need to use this function.
- Perform a functional test after learning function is set.

How does the system work (Front system)

Driving forward, press footbrake

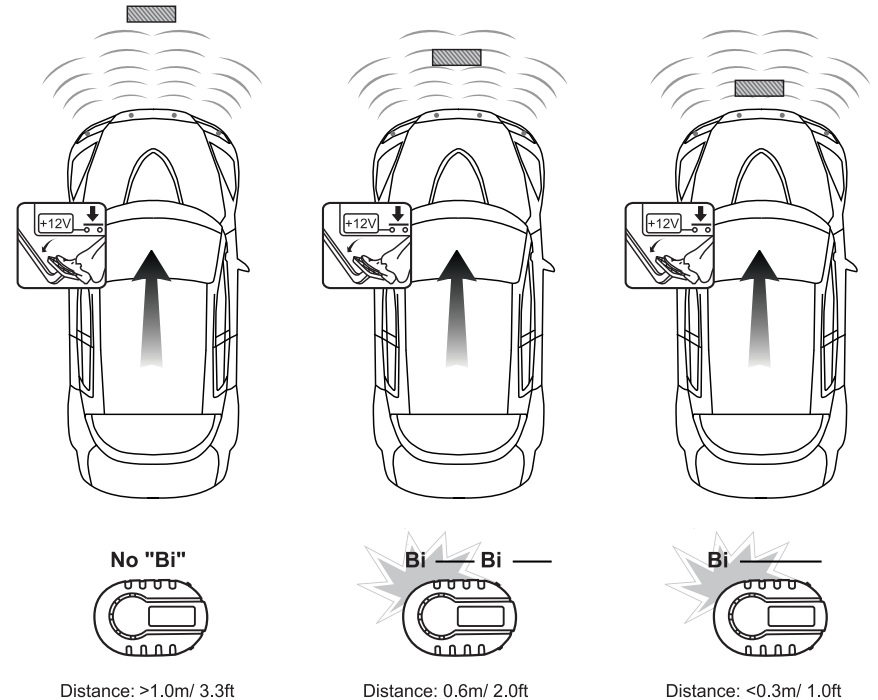

Note: The max. detection range of outside sensors (A&D) sensors are 0.69m/ 2.3ft.
The max. detection range of central sensors (B&C) sensors are 0.89m/ 2.9ft.

Reversing (The function cannot be used when connecting a display set)

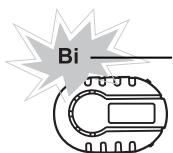
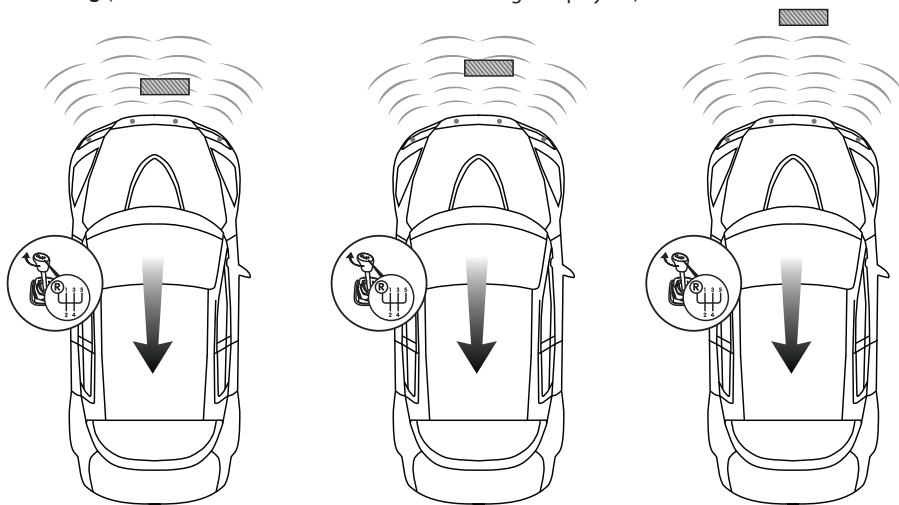

Distance: <0.3m/ 1.0ft

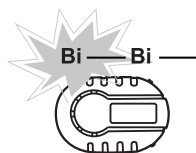

Distance: 0.4m/ 1.3ft

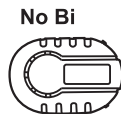

Distance: >0.7m/ 2.3ft

Note: The max. detection range of outside sensors (A&D) sensors are 0.69m/ 2.3ft.
The max. detection range of central sensors (B&C) sensors are 0.59m/ 1.9ft.

How does the system work (Rear system)

Reversing

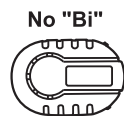
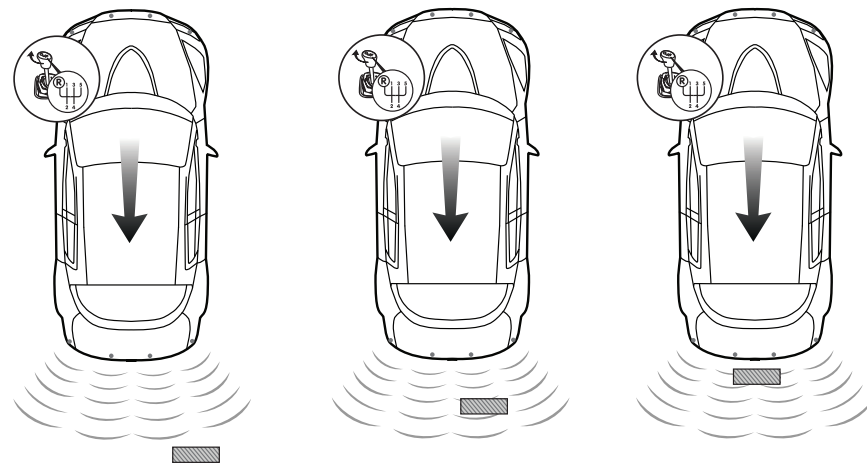

Distance: >1.5m/4.9ft

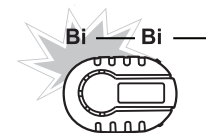

Distance: 0.6m/ 2.0ft

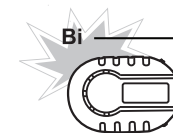

Distance: <0.3m/ 1.0ft

Note: The max. detection range of outside sensors (A&D) sensors are 0.99m/ 3.2ft.
The max. detection range of central sensors (B&C) sensors are 1.49m/ 4.9ft.

Different scenarios for system with buzzer (Front system)

Braking:

Buzzer	
No Bi	0.90~0.99m / 3.0~3.2ft
Bi---Bi---	0.80~0.89m / 2.6~3.0ft
Bi---Bi---	0.60~0.79m / 2.0~2.6ft
Bi--Bi-	0.40~0.59m / 1.3~2.0ft
Bi-Bi-Bi-Bi-	0.30~0.39m / 1.0~1.3ft
Bi-----	<0.30m / 1.0ft

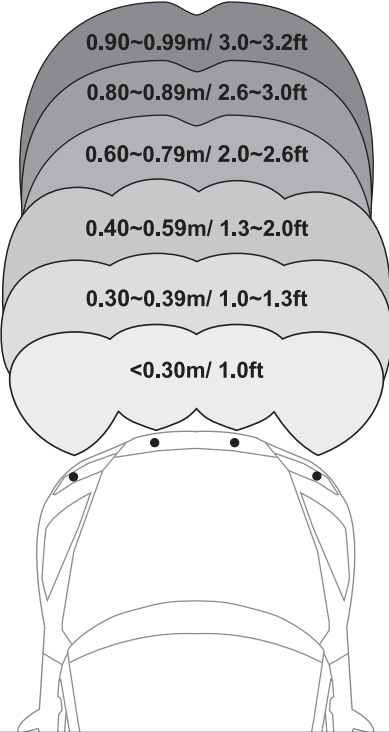

Reversing:

Buzzer	
No Bi	> 0.69m / 2.3ft
Bi---Bi---	0.50~0.69m / 1.6~2.3ft
Bi--Bi-Bi-	0.40~0.49m / 1.3~1.6ft
Bi-Bi-Bi-Bi-	0.30~0.39m / 1.0~1.3ft
Bi-----	<0.3m / 1.0ft

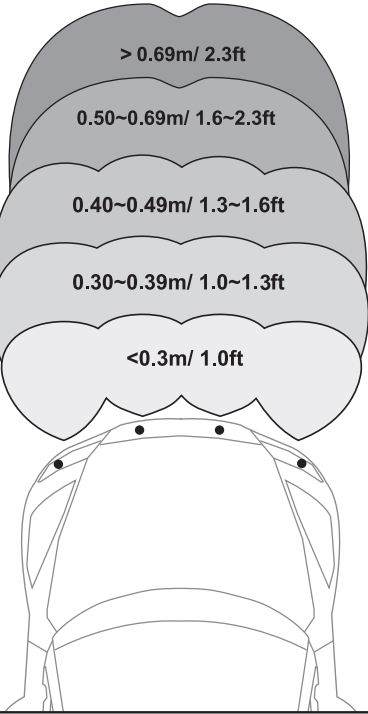

Different scenarios for system with buzzer (Rear system)

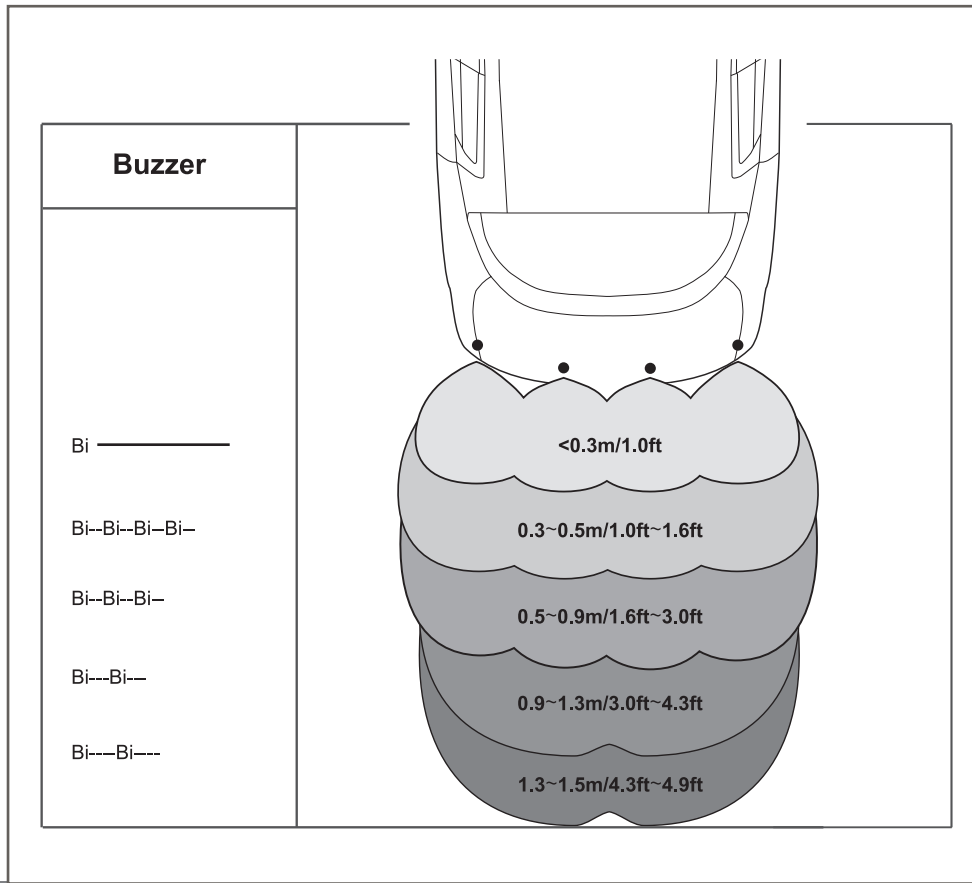

Attention

False detection may occur in the following situations:

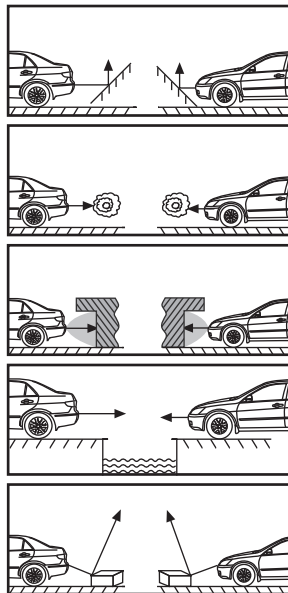

- After installation, please perform a functional test before use
- Heavy rain, dirty or damaged sensors may cause in false alarm occasionally
- Ensure that the self-testing procedure is completed and all sensors are function properly before using the system

Sensor maintenance

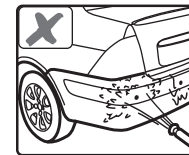
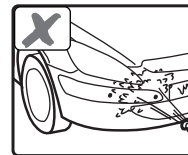

Do not wash the sensor with a pressure washer or scrub them forcibly.

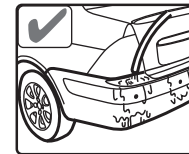
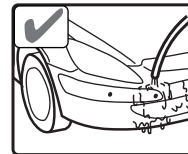

Please wash car with low-pressure spray.

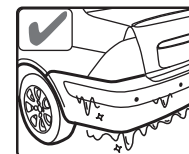
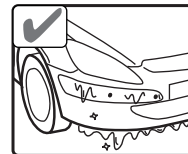

Please melt the snow with water when the sensors are covered.

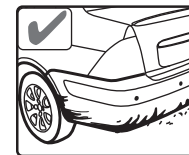
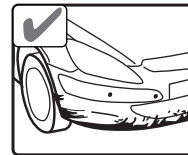

Please clean the sensors with cloth or low-pressure spray when the sensors are covered by dirt.

Installation Manual

Brief installation diagram

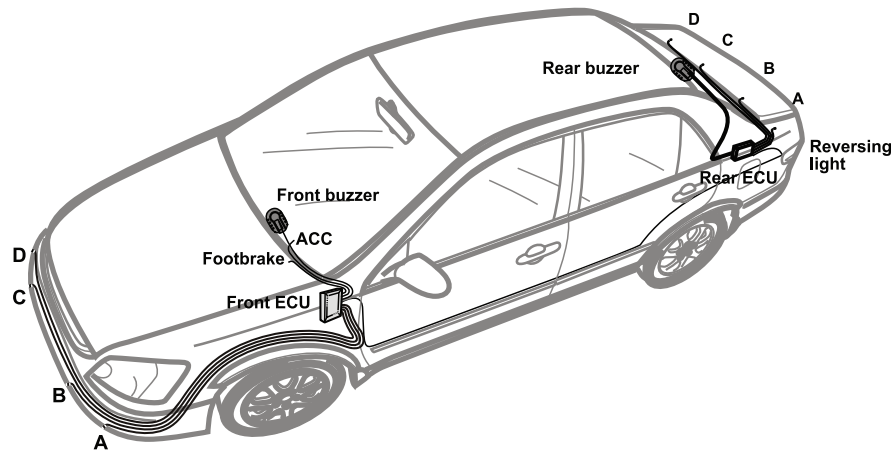

Includes

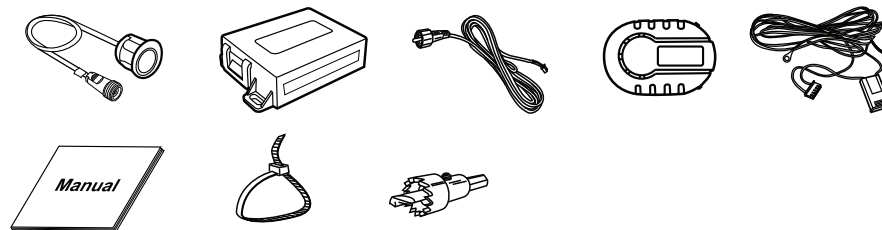

※ The above graphics are for reference only.

Installation tools

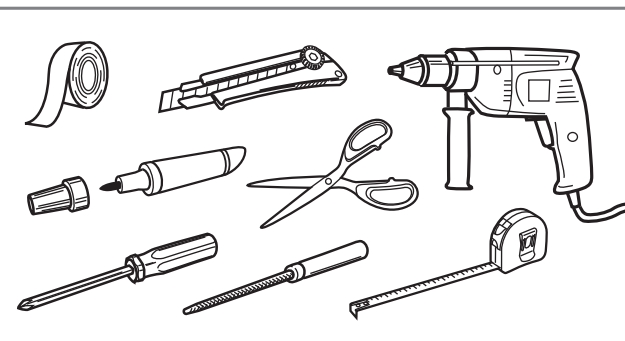

60' ~ 80'

Sensor installation

1 The sensor head angle can be changed to compensate for angled bumpers. Please see the instructions overleaf.

Diagram 1 illustrates the sensor installation process based on bumper height (H) and bumper length (L). It includes three vertical panels showing correct and incorrect sensor placement relative to bumper height, and a detailed top-down view of sensor placement on a bumper.

Height Requirements:

- Correct: $H > 45\text{cm}/1.5\text{ft}$ and $H < 65\text{cm}/2.1\text{ft}$. (Indicated with a checkmark)
- Incorrect: $H < 45\text{cm}/1.5\text{ft}$. (Indicated with an 'X')
- Incorrect: $H > 65\text{cm}/2.1\text{ft}$. (Indicated with an 'X')

Length Requirements:

- Correct: Three segments of length $< 45\text{cm}/1.5\text{ft}$ are shown between sensor positions.

Top-down View:

- Total bumper length: L
- Vertical sensor placement range: $45\text{cm}/1.5\text{ft} < H < 65\text{cm}/2.1\text{ft}$
- Horizontal sensor placement segments: c, b, a, a, b, c
- Formulas for segment lengths:
 - $a = 1/8L$
 - $b = 2/8L$
 - $c = 1/8L$

Diagram 2 illustrates the sensor installation process based on sensor angle and bumper length (L). It includes three vertical panels showing correct and incorrect sensor angles, and a detailed front view of the car with sensor positions marked.

Angle Requirements:

- Correct: Sensor angle $< 1.0\text{m}/3.3\text{ft}$ from horizontal. (Indicated with a checkmark)
- Correct: Sensor angle $< 1.5\text{m}/4.9\text{ft}$ from horizontal. (Indicated with a checkmark)
- Incorrect: Sensor angle $> 1.5\text{m}/4.9\text{ft}$ from horizontal. (Indicated with an 'X')

Placement Guidelines:

- Correct: $35\text{cm}/1.1\text{ft} < L_1 < 45\text{cm}/1.5\text{ft}$ and $45\text{cm}/1.5\text{ft} < L_2 < 55\text{cm}/1.8\text{ft}$
- Correct: $45\text{cm}/1.5\text{ft} < H < 65\text{cm}/2.1\text{ft}$

Front View Labels:

- Sensor positions: A, B, C, D
- Distances: L_1 (between A-B and C-D), L_2 (between B-C)
- Height: H

Notes:

- For 2-sensor front sensor system, recommended to install 2 sensors on position E&H for the best performance.
- On some vehicles, due to the number plates location or bumper design, the distance between the centre of two sensors (L_2) will be greater, i.e. $L_2 > 60\text{cm}$. The kit will still function, however the detection of narrow objects i.e. posts will be reduced.

3 Change of sensor cover.

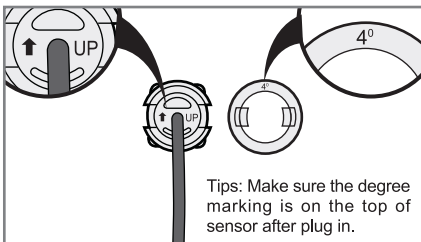
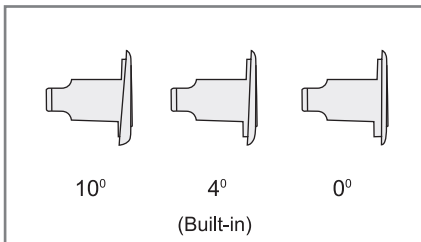
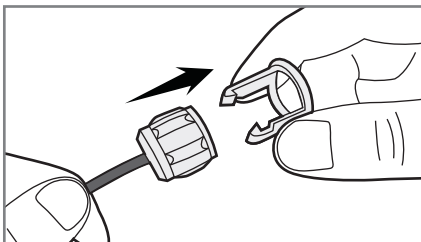
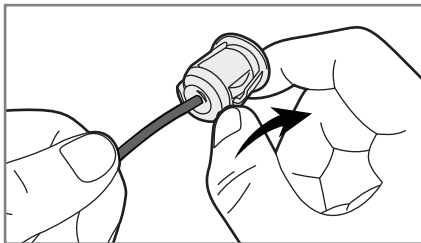
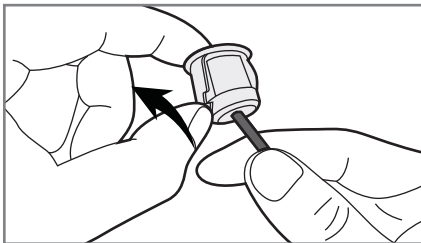

Tips: Make sure the degree marking is on the top of sensor after plug in.

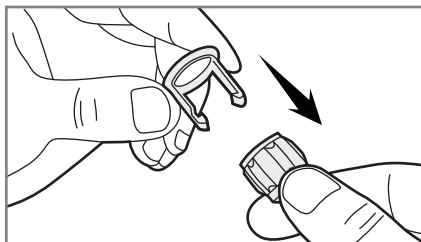

4

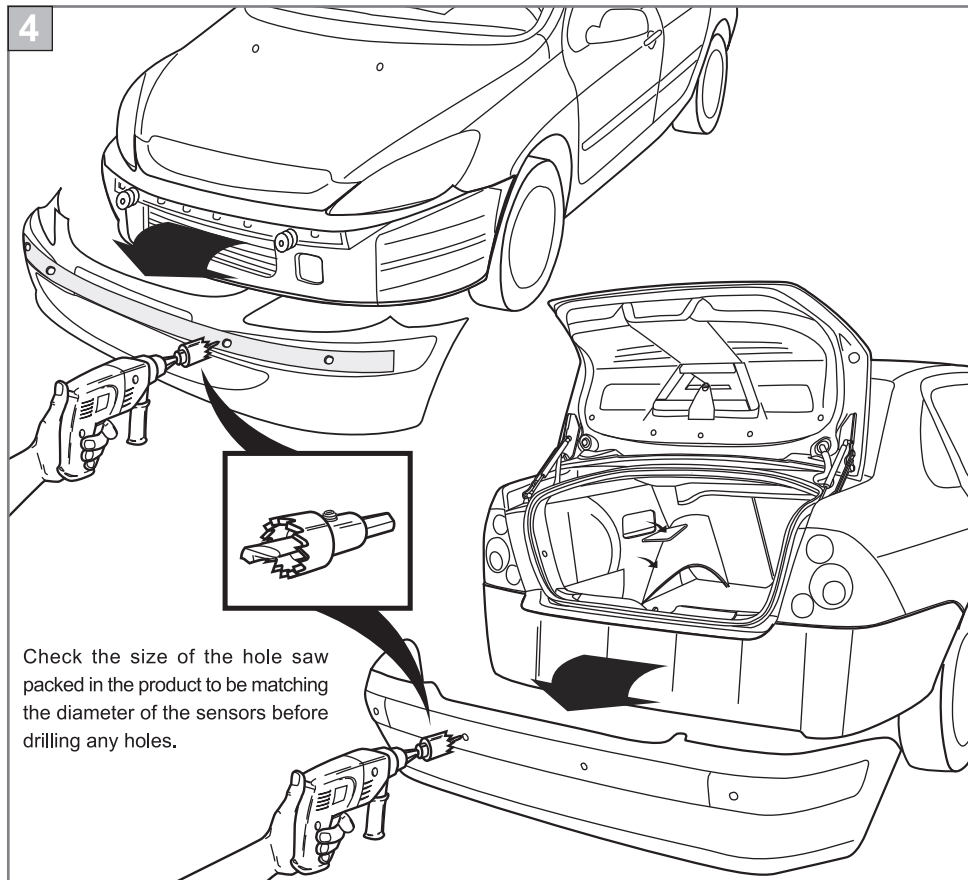

Check the size of the hole saw packed in the product to be matching the diameter of the sensors before drilling any holes.

5 Hint: If a gap found between bumper and 10° sensor cover after installation, please adjust the angle of the hole shown as below.

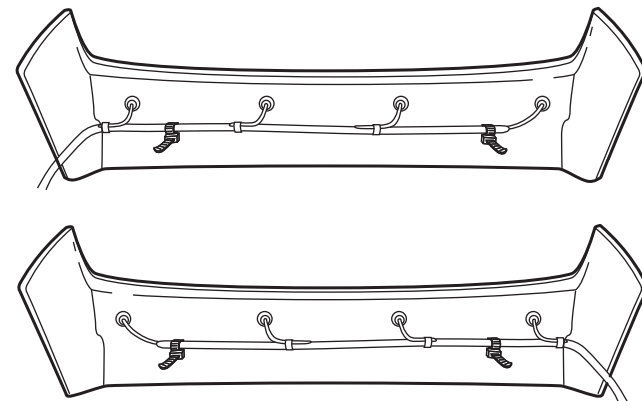
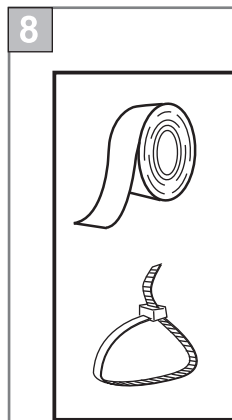
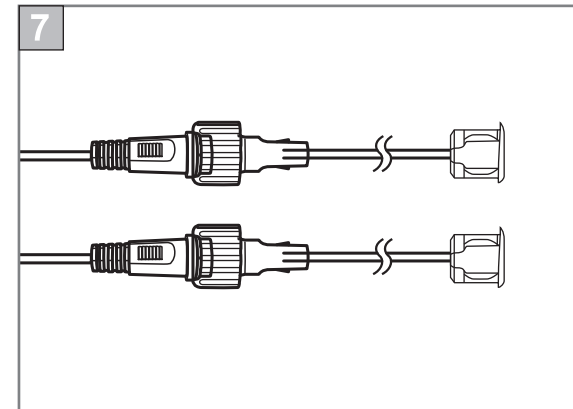
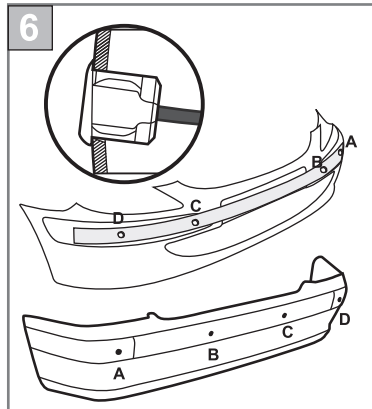
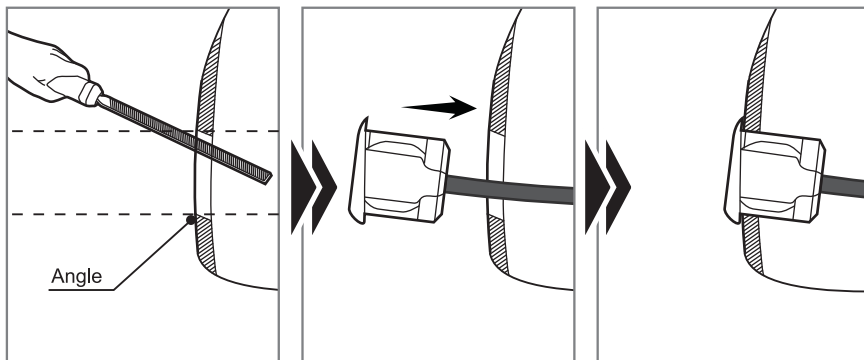
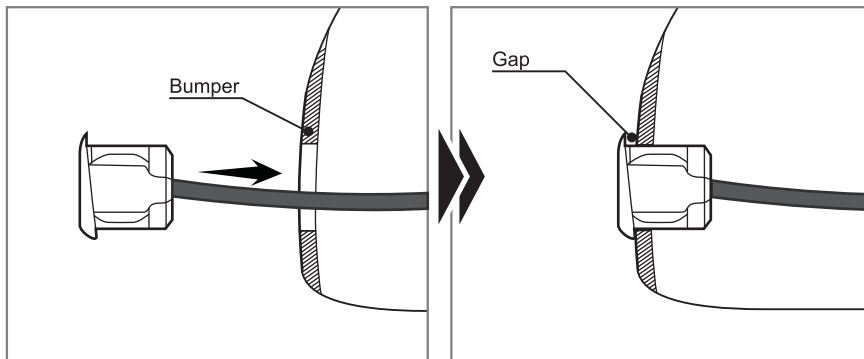

9

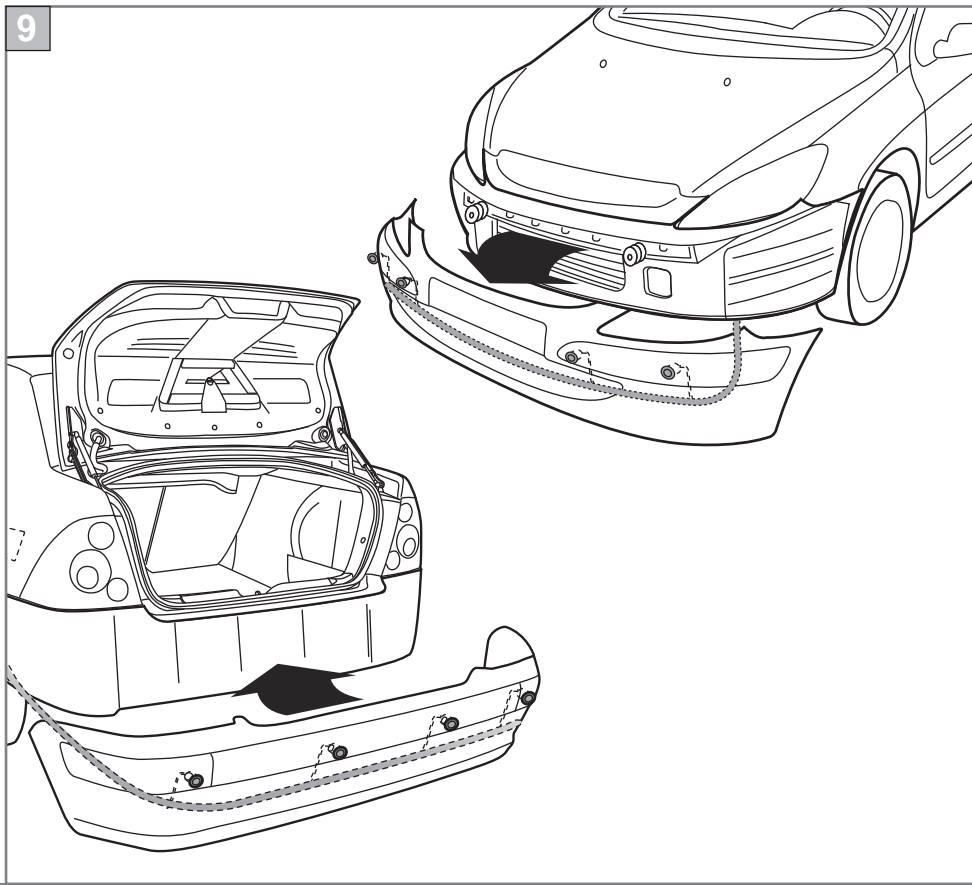

Buzzer installation

Front buzzer installation

A

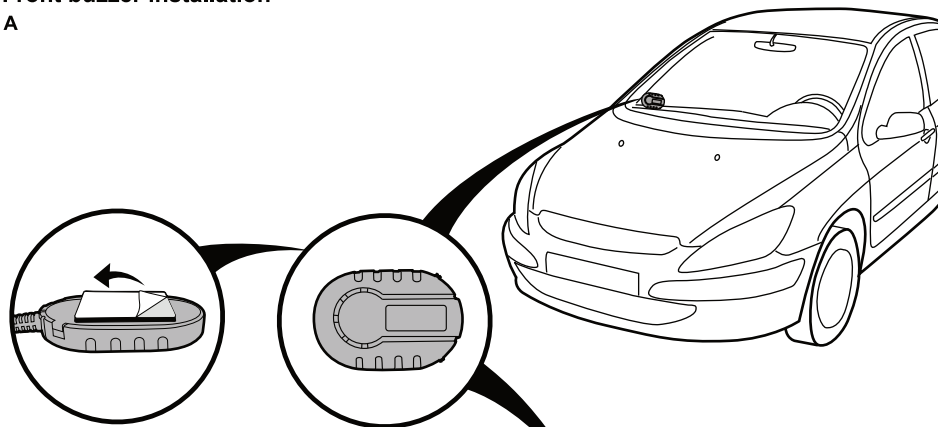

Rear buzzer installation

B

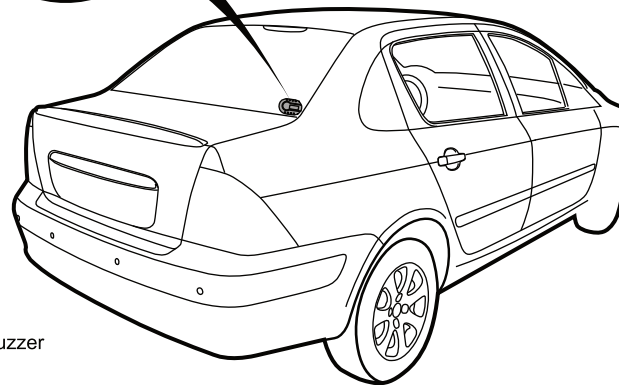

The above are the recommended buzzer installation locations.

Wiring diagram (Front ECU)

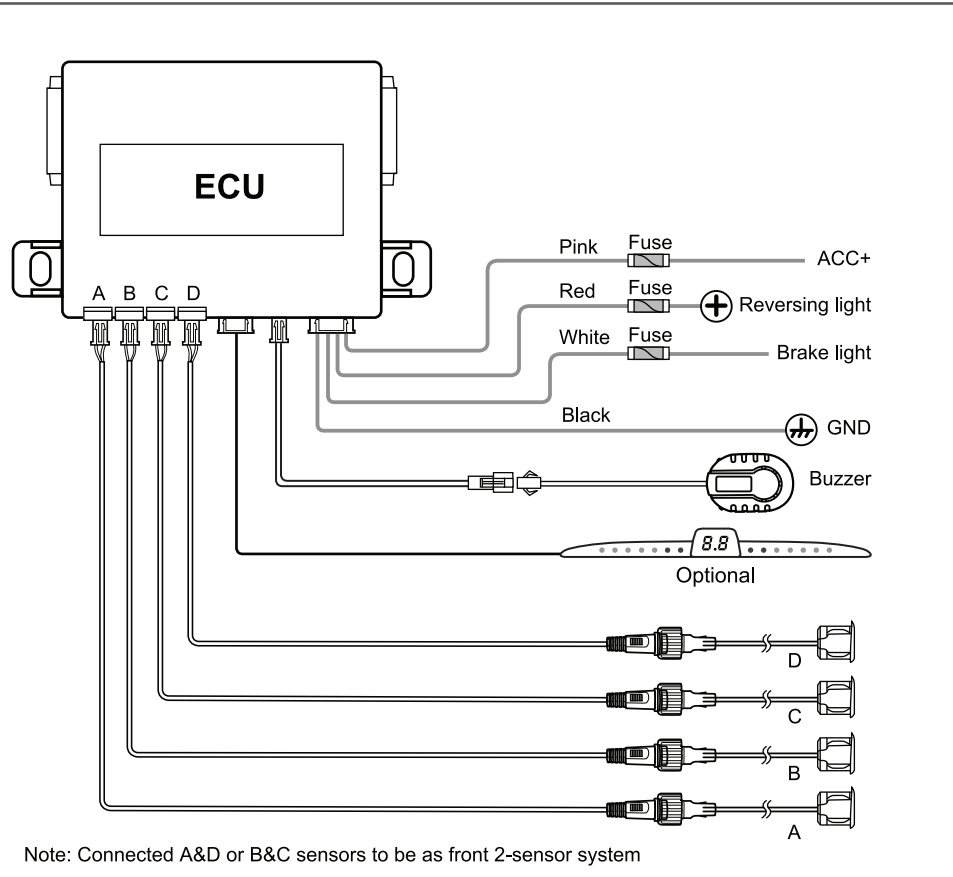

Wiring diagram (Rear ECU) 1

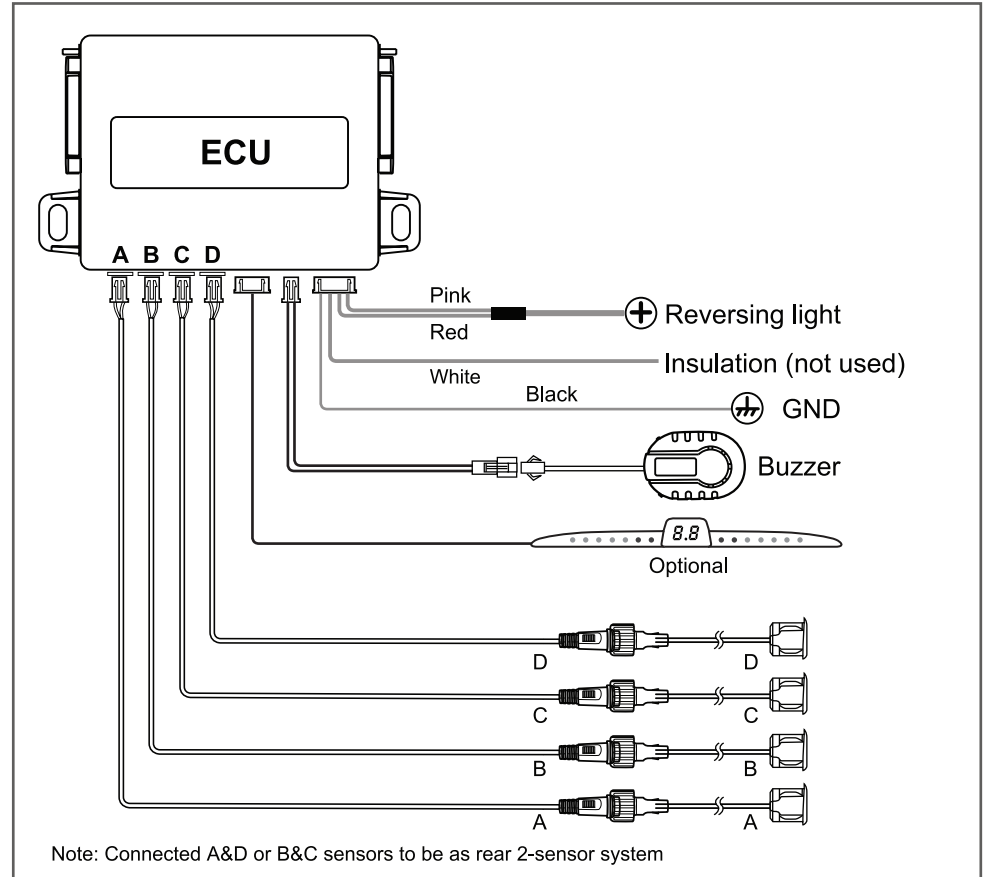

Wiring diagram (Rear ECU) 2

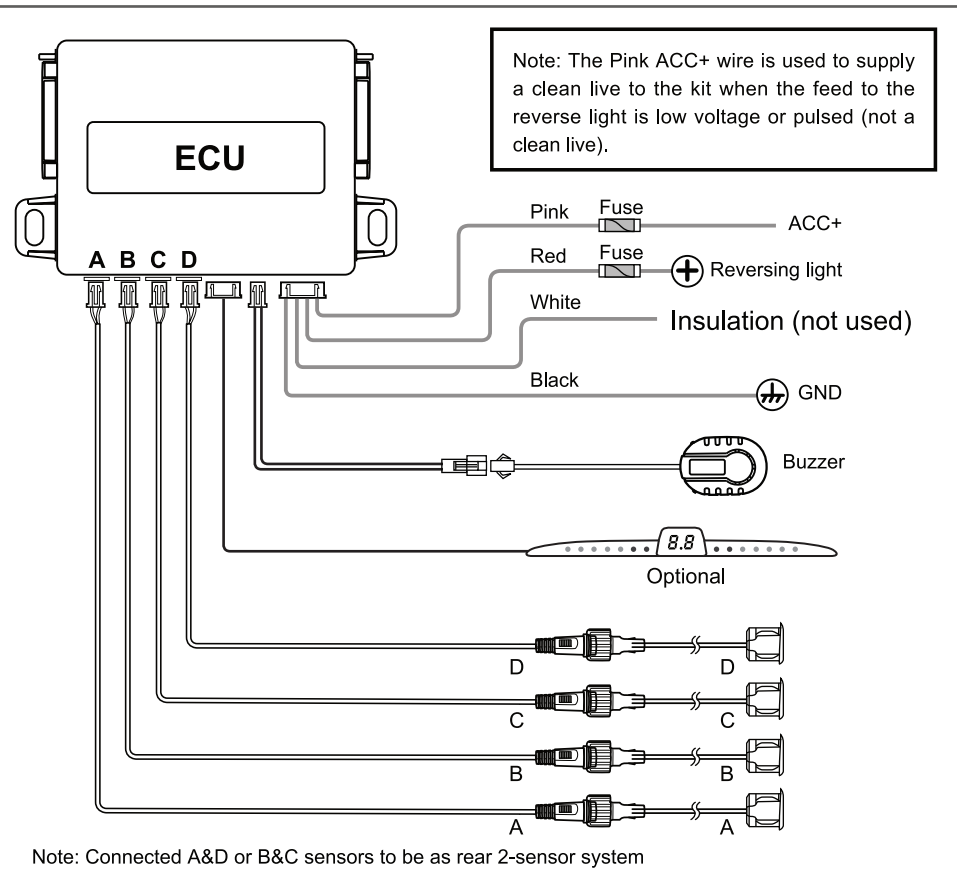

Functional test

Functional testing is performed by holding a wooden board (0.3 x 1.0m/1x3.3ft) standing at the front or rear of the car, and drive the car forward and backward to test each function respectively as shown in this manual.

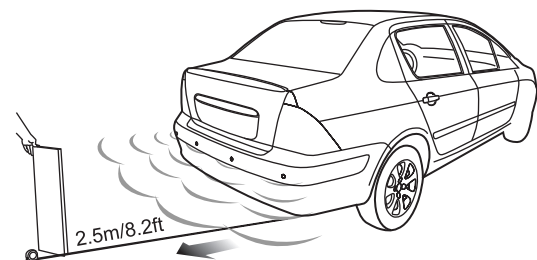

Rear sensor functional test

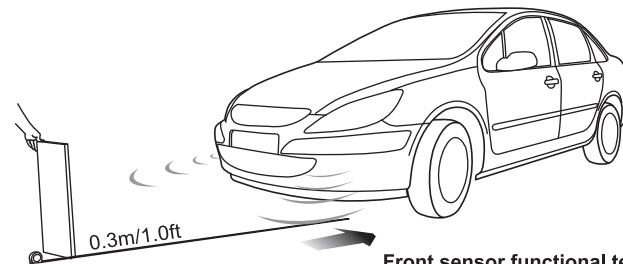
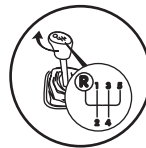
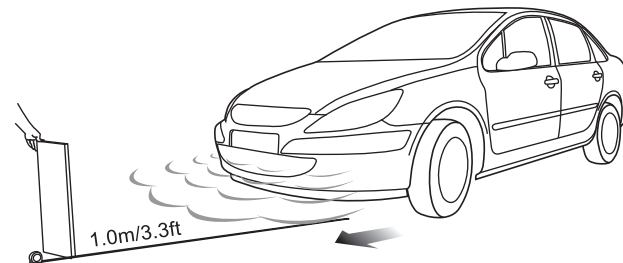

Front sensor functional test

Troubleshooting

1. After installation, the buzzer doesn't work.

- Make sure the wires connected properly
- Make sure the vehicle is ACC ON
- Make sure the reverse gear is selected (the reversing light should be lighted on)

2. Damaged sensor detected

- Make sure ALL sensors plugged into the ECU correctly and tightly
- Make sure no snow or dirt covered on the sensor
- Please check the sensor is damaged or not

3. False alarm

- Make sure ALL sensors plugged into the ECU in the correct position tightly
- Please check if any of sensors detected the ground
- Please check if the rubber ring of the sensor came out (if sensor comes with rubber ring)

4. Buzzer alarm sound is too low or too high

- Press volume button to adjust the volume to a suitable level.

5. Learning function is invalid

- Sensor(s) is/are damaged
- Make sure ALL sensors plugged into the ECU correctly and tightly

6. If the problem persists, please follow below.

- For consumer: Please contact the nearby dealer or customer service center
- For installer/dealers:
 - a. Test the sensors with a certified ECU by performing a functional test.
 - b. Replace another ECU and retest the sensors
Plug the certified sensors into the ECU and performing a functional test again
Please email us at customerservice@steel-mate.com about the problems with details